

Application of Standard and Modified Eh-Star Test Method for Induction Motor Stray Load Losses and Efficiency Measurement

Branko Koprivica¹, Milos Božić¹, Marko Rosić¹, Miroslav Bjekić¹

Abstract: The aim of this paper is to present the application of one simple and accurate method for the measurement of stray load losses (additional load losses) in induction machines. That is the Eh-Star method given in the IEC 60034-2-1 standard. In this paper the theoretical background of the method and the measurement procedure have been explained. All measurements have been performed using modern measurement systems based on a personal computer, data acquisition cards and LabVIEW software. According to the measured results for the stray load losses, the efficiency of the induction motor has been calculated. The efficiency obtained has been compared with the IEC standard efficiency classes, in order to determine the efficiency class of the tested motor. Additionally, measurements have been performed using the modified Eh-Star method. The results obtained have been compared with those obtained using the Eh-Star method. The advantages and disadvantages of both methods have been analysed in this paper.

Keywords: Induction motor, Stray load losses, Eh-Star method, Energy efficiency, LabVIEW.

1 Nomenclature

f – the supply frequency [Hz];	P_1 – the input power [W];
n – the operating speed [rpm];	P_T – the total loss [W];
p – the number of pole pairs;	P_{fe} – the iron loss [W];
P – the power [W];	s – the slip;
P_δ – the air gap power [W];	I_N – the rated current [A];
U_i – the inner phase voltage [V];	I_0 – the no-load current [A];
P_N – the rated power [W];	I_t – the test current [A];
P_r – the rotor winding loss [W];	I_i – the inner phase current [A];
P_s – the stator winding loss;	η – the efficiency [%];

¹University of Kragujevac, Technical Faculty Cacak, Svetog Save 65, 32000 Cacak, Serbia;
E-mails: koprivica@tfc.kg.ac.rs; mbozic@tfc.kg.ac.rs; mrosic@tfc.kg.ac.rs; mbjekic@tfc.kg.ac.rs

P_{fw} – the friction and windage loss [W];

P_{LL} – the stray load (additional) loss [W];

R_{eh} – the additional resistor in the Eh-star test [Ω];

U_N – the rated terminal voltage [V];

R_S – the single phase stator winding resistance [Ω];

I_{ref} – the reference current during the Eh-Star test [A];

$P_{e,in}$ – the measured input power [W];

I_U, I_V, I_W – the measured line currents [A];

U_{UV}, U_{VW}, U_{WU} – the measured line-to-line voltages [V].

2 Introduction

For past two decades energy efficiency has been a matter of interest in all developed countries, and more recently across the whole world. Great attention has been devoted to the efficient use of electrical energy. Considering that most electrical energy is consumed in electrical drives, improvement of electrical machines plays a leading role in the increasing electric energy efficiency. In the last few years, developments in motor design and manufacturing techniques have resulted in improvements that have increased efficiency to over 90%. With this improved efficiency, the accurate measurement of stray load losses is very important. Some previously standardised methods were too inaccurate, and others too expensive. Therefore, it has been necessary to find a new method to overcome these problems. This has been a challenge for the IEC Standards Organization, national organisations and manufacturers, which has been solved by introducing one already known measurement procedure. This procedure, previously introduced in [1], allowed much simpler measurements, but the calculation of the stray losses was complicated. Nowadays, this can be easily overcome by using a PC. So this method, called the Eh-Star method, has been implemented in a new IEC 60034-2-1 standard [2] which was published in 2007. Its circuit gives an unbalanced voltage supply for a three-phase induction motor through additional resistance in the third phase. By using this method the stray load losses can be measured without coupling the machine to a dynamometer or auxiliary machine.

Since the new IEC standard has been published, the Eh-Star method has been the subject of research of many scientists and engineers [3 – 7]. This method has been compared with other standard methods, and many positive conclusions have been obtained [8 – 11]. Principally, this method has been compared with the input-output test (residual loss method) and reverse rotation test, according to IEC 61972 and IEEE 112 standards [12, 13]. Many advantages of the Eh-Star method are referred to as reasons why the use of this

method is good for determining additional losses. A short measurement time, low energy consumption, low cost, good reliability and high accuracy have been the foremost reasons why the Eh-Star method has already been accepted by manufacturers and beneficiaries. Because of this it can be expected that the Eh-Star measurement setup and procedure will be often used as a basis for induction motor efficiency measurements in laboratories all over the world.

Furthermore, this method will be more and more tested in the future and its evolution can be expected. In addition, it is possible to expect the development of completely new measurement methods which are created as a result of research on the Eh-Star method. One modification has already appeared in the literature [6], and it has also been considered in this paper. This method eliminates the additional resistance from the test circuit and, instead of the third phase, includes a generator neutral. It has been shown that the results obtained by this method do not differ significantly from those obtained by the Eh-Star method.

The application of the Eh-Star method for the measurement of the stray load losses of induction motors, given by the IEC 60034-2-1 standard, has been presented in this paper. Since this method requires comprehensive and complicated measurements and calculations, the idea was to adapt it to a personal computer and LabVIEW based measurement system. Therefore, the entire measurement procedures, including the Eh-Star test, the no-load test, the short circuit test and the load test, have been implemented in a LabVIEW program. All measurements and calculations have been performed within a computer program in order to minimise the possibility of errors in the readings and calculations, and to achieve savings in time. As a result of the Eh-Star test the stray load losses have been obtained. These losses, along with all the other losses obtained from other measurements, have been used for obtaining the induction motor efficiency. All measured and calculated results have been saved to a computer as a final test report in Microsoft Office format. The measurement setup, LabVIEW program, principal calculations and main results have been presented and discussed in this paper.

2.1 Efficiency of the induction machine

The efficiency of the induction machine can be calculated from the input power P_1 and total power losses P_T as:

$$\eta = \frac{P_1 - P_T}{P_1}, \quad (1)$$

where $P_T = P_{fe} + P_{fw} + P_r + P_s + P_{LL}$. Since the determination of the additional losses is most difficult in this case, it has been further demonstrated how they can be determined using the Eh-Star method.

2.2 Stray Load losses calculation by the Eh-Star method

By using the Eh-Star method, the stray load losses in the induction machines can be calculated by:

$$P_{LL} = k \left[(1-s)(P_{\delta 1} - P_{\delta 2}) - P_{fw} \right], \quad (2)$$

where $k = 1/\left[1 + (I_{i1}/I_{i2})^2\right]$, $P_{\delta 1} = 3 \operatorname{Re}\{U_{-i1} I_{-i1}^*\}$, $P_{\delta 2} = 3 \operatorname{Re}\{U_{-i2} I_{-i2}^*\}$ (indexes 1 and 2 are for the positive and negative sequence system).

Voltages U_i and currents I_i can be determined from measured voltages and currents during the test according to IEC 60034-2-1 – Annex B [2].

2.3 Eh-Star test and measurement setup

The measurement setup for the Eh-Star test, according to [2], has been presented in Fig. 1.

The uncoupled motor in the star connection is operating with an unbalanced voltage supply, and the switch is in position 2. A star point must not be connected to a system neutral or earth in order to avoid zero-sequence currents.

The third motor phase should be connected to the power supply across a resistor R_{eh} which has as typical value:

$$R'_{eh} = \frac{0.2 U_N}{\sqrt{3} I_N}. \quad (3)$$

The resistor R_{eh} has to be adjusted during the test so that the positive sequence current I_{i1} stays below 30% of the negative sequence current I_{i2} and the speed stays in the range of typical motor speeds near the rated speed. It has been recommended to begin the test with an actual resistor R_{eh} that differs no more than 20% from the typical value R'_{eh} .

The motor should be started without the R_{eh} resistor at a reduced voltage (25–40% U_N) to run-up. After that, the R_{eh} resistor should be connected (smaller motors may be started with a R_{eh} resistor already connected).

When this has been done, the supply voltage should be varied so the test includes six points. The points should be chosen to be approximately equally spaced between 150% and 75% of the rated phase current measured in phase V (I_V). At each point all line currents, line voltages, power and speed (I_U , I_V , I_W , U_{UV} , U_{VW} , U_{WU} , $P_{e,in}$, n) should be recorded.

The test circuit presented in Fig. 1 has been used for the development of test circuits based on modern data acquisition systems. A new test circuit has been presented in Fig. 2. Also, the circuit in Fig. 1 has been changed as

proposed in [6], in order to include both a standard and modified Eh-Star test circuit. The modified method eliminates R_{eh} and provides the unbalanced supply for the motor from two phases and the generator neutral. The elimination of the additional resistance from the original test circuit may be practical when low power motors are tested. In this case the value of the additional resistance may be significant and, considering the currents during the test, it is not always easy to obtain such a resistance. Also, the inclusion of the generator neutral is easy. So, the zero conductor and third port of the switch has been inserted in the new test circuit. Besides this there is no need for additional elements or instruments, and all measurements and calculations can be performed using the same apparatus and computer program as for the Eh-Star test.

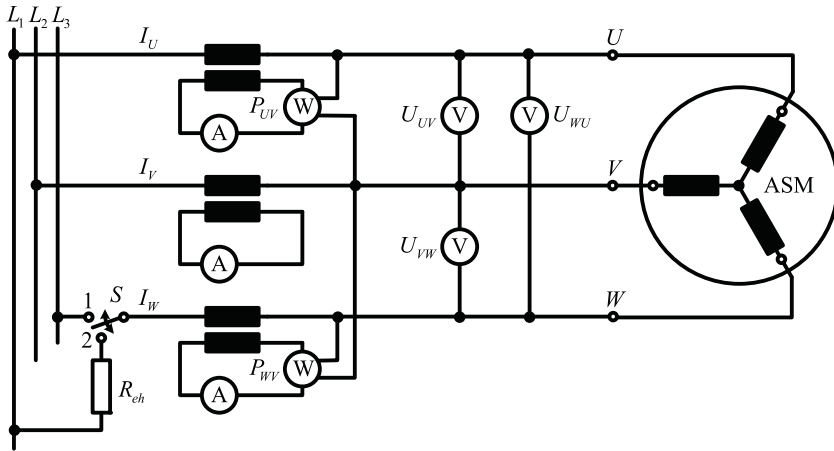

Fig. 1 – *Eh-Star test circuit.*

The new measurement system consists of a personal computer with LabVIEW software, a National Instruments NI cDAQ-9172 chassis with NI 9225, NI 9227 and NI 9402 data acquisition cards, current transformers and a three-phase adjustable voltage power supply connected to the tested induction motor. Phase currents have been connected to the current transformer. The secondary currents of the current transformers have been connected to the analog inputs of the NI 9227 card. Line voltages have been connected to the analog inputs of the NI 9225 card. In order to measure the motor speed a simple method has been used. A small permanent magnet has been mounted on the motor shaft, and a Hall sensor has been placed below, very close to the shaft. The sensor registers a change in the magnetic field during the passage of the permanent magnet and creates an impulse every time this occurs. The impulses created have been transmitted to the NI 9402 card which gives the frequency of the appearance of these impulses. This frequency has been converted into the motor speed. These three cards have been placed in a NI cDAQ 9172 chassis

which has been connected to a PC through a USB connection. The analog inputs of these cards have been called and read using a LabVIEW application made specifically for this purpose. In order to perform a load test of the motor a mechanical brake has been mounted on the motor shaft. The complete laboratory measurement setup is presented in Fig. 3.

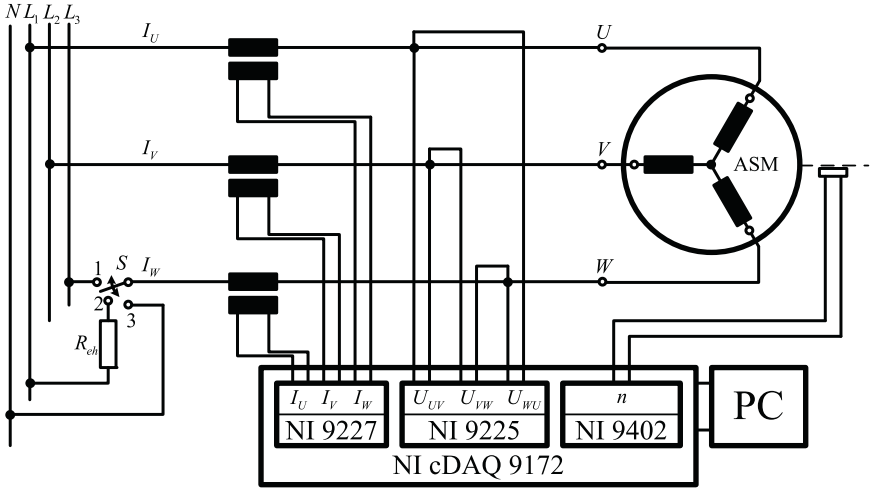

Fig. 2 – PC based Eh-Star test circuit.

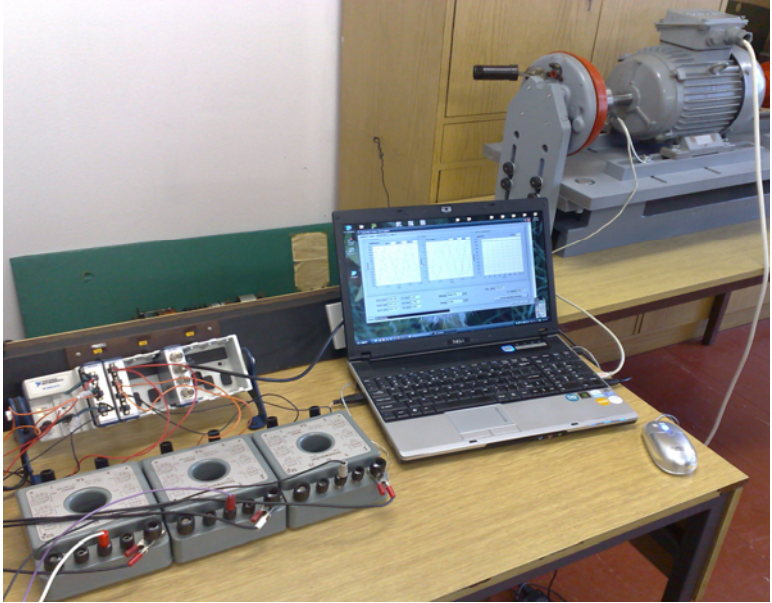
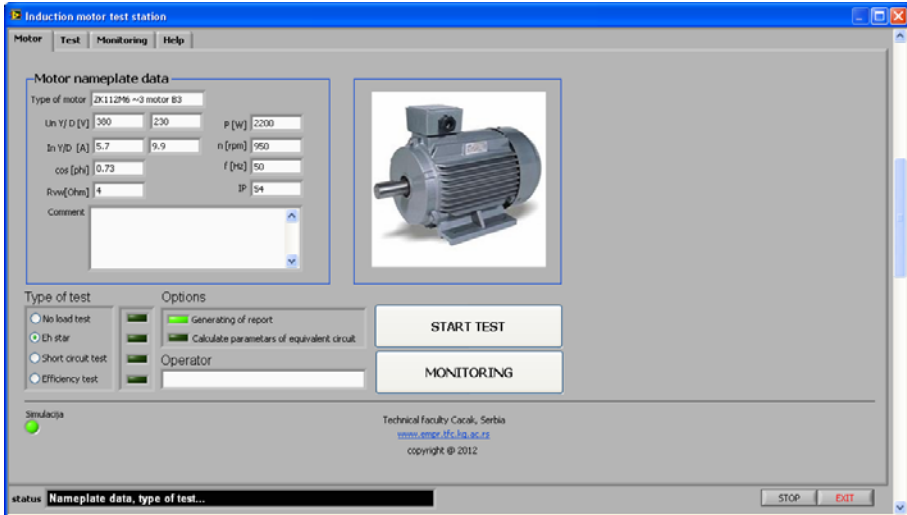

Fig. 3 – Laboratory test setup.

2.4 LabVIEW application

A LabVIEW application has been developed with the intention to perform all necessary measurements and calculations required for the Eh-Star test. Voltages U_{UV} , U_{VW} , U_{WU} , currents I_U , I_V , I_W and speed n have been measured, and power $P_{e,in}$ has been calculated.



(a)

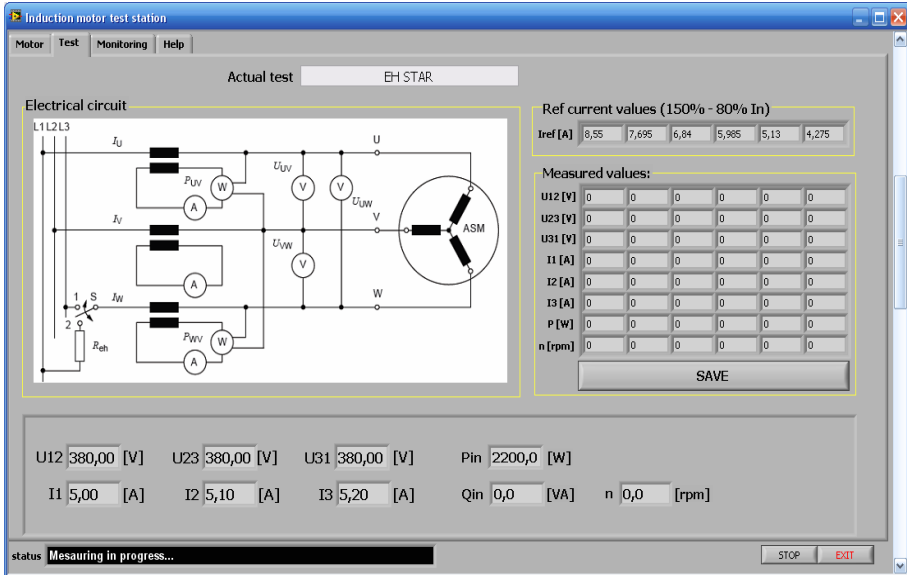

(b)

Fig. 4 – LabVIEW application for Eh-Star test: (a) initial tab; (b) test tab.

This has been performed for six test points as described in the previous section. Values of these quantities have been stored for each point. After the measurement is completed the necessary calculations are performed by the application.

The application starts in an initial Motor tab where the operator enters the required nameplate data for the test motor (motor voltage, current, power, speed and others), as presented in Fig. 4a. In this tab the operator selects the test to be performed. After selecting the START TEST button the program switches to the Test tab, as presented in Fig. 4b.

Current values of all measured quantities and the value of calculated power can be read in this tab. Using this tab the operator performs a series of measurements (in our case six measurements). When performing the Eh-Star test the operator adjusts the input voltage to achieve the desired current value, e.g. 150% of the rated phase current measured in phase V for the first test point. Then the SAVE button can be selected, which saves all measured quantities and performs all necessary calculations. At the end of the measurement the application plots diagram $P_{LL} = f((I_N/I_t)^2)$, where $I_t = \sqrt{I_N^2 - I_0^2}$. This diagram, along with other significant data, is saved as Excel and Word documents in the computer memory. This document presents the Eh-Star test report which consists of all data of interest.

Using this application all tests needed for the measurement of the efficiency of the induction motor can be performed.

2.5 Measurement results

All measurements have been performed on a motor with the nameplate data given in **Table 1**.

Table 1
Motor nameplate data.

Input data								
U_N [V]	I_N [A]	I_0 [A]	I_t [A]	P_N [kW]	$2p$	n_N [rpm]	$P_{e,in}$ [Hz]	R_S [Ω]
380	5.7	3.93	4.128	2.2	6	950	50	2

The stator winding resistance has been measured before and after measurements, and is found to be 2Ω . No-load test has been performed to obtain the iron losses P_{fe} and the friction and windage losses P_{fw} . The friction

and windage losses have been determined by plotting a curve of constant losses against the voltage squared as a straight line and extrapolated to zero voltage. By subtracting this loss and the stator winding loss from the measured power, at the rated voltage, the iron loss has been determined. The results obtained are $P_{fe} = 136.47 \text{ W}$ and $P_{fw} = 27.38 \text{ W}$.

Before starting the Eh-Star test the additional resistance R'_{eh} has been calculated using (3). The calculated value is 7.698Ω . When this resistance has been used the I_{i1} has a value greater than $0.3I_{i2}$ [2]. So, the higher resistance has been used in further measurements to investigate the influence of this resistance on the measured results. Stray load loss data has been calculated for the six test points and then fitted using the linear function $y = Ax + B$. The obtained variation of ratio I_{i1}/I_{i2} and coefficients A and B with R_{eh} have been presented in **Table 2**. The value of the resistance has an influence on the ratio I_{i1}/I_{i2} , which should be below 0.3, and consequently on the result of the stray load losses (A and B). It can be seen that the achievement of $I_{i1}/I_{i2} = 0.3$ at all test points is not possible, especially for the sixth test point and lowest test current. In this case the best ratio obtained in the sixth test point is 0.3 for $R_{eh} \approx 19 \Omega$. A relative deviation of slope A to slope A_{19} (obtained for $R_{eh} \approx 19 \Omega$) has also been presented in this table. This deviation is small in most test points when ratio I_{i1}/I_{i2} is above 0.3.

Table 2
Variation of ratio I_{i1}/I_{i2} , A and B with R_{eh} .

R_{eh} [Ω]	I_{i1}/I_{i2}						A	B	$100(A - A_{19})/A_{19}$
7	0.32	0.32	0.34	0.35	0.38	0.44	30,7082	-4,3371	3.985
8	0.31	0.31	0.32	0.34	0.36	0.41	30,3281	-3,6552	2.698
10	0.29	0.29	0.30	0.31	0.33	0.37	30,4755	-4,3182	3.197
12	0.28	0.28	0.28	0.29	0.30	0.32	29,0757	-2,0937	-1.543
13	0.27	0.28	0.28	0.29	0.29	0.32	29,4573	-1,4276	-0.251
14	0.27	0.28	0.28	0.28	0.29	0.31	28,9324	-1,1814	-2.028
15	0.27	0.27	0.28	0.28	0.29	0.31	29,0125	-1,0582	-1.757
16	0.28	0.28	0.28	0.28	0.29	0.30	28,0269	-1,7090	-5.094
19	0.29	0.29	0.28	0.29	0.29	0.30	29,5314	-0,9384	0
21	0.30	0.29	0.29	0.29	0.30	0.30	27,7691	-0,1391	-5.967
22	0.30	0.30	0.30	0.30	0.30	0.31	27,3867	-1,2684	-7.262

The results obtained from the Eh-Star test, when $R_{eh} \approx 19 \Omega$, have been presented in **Table 3**. Also, the calculated output data have been presented in this table.

After a linear fit for the six test points, the diagram for $P_{LL} = f\left(\left(I_{i2}/I_t\right)^2\right)$ has been obtained. This diagram has been presented in Fig. 5. It also presents the measurement results for the six test points and corrected linear functions without offset B (\blacklozenge are the measurement results, the solid line is for linear fit and the dashed line is the corrected linear fit without offset). The offset B must be omitted, as at zero torque, which corresponds to the zero load current, the stray load losses shall be zero (this reduces the effect of random errors in the test measurements). The stray load losses for rated load have been taken from the slope, so $P_{LL} = 29.531 \text{ W}$.

Table 3
Eh-Star test results.

Input data						
$I_{ref} [\text{A}]$	8.55	7.70	6.84	5.99	5.13	4.28
$U_{UV} [\text{V}]$	230.53	208.55	185.21	160.54	138.12	114.79
$U_{VW} [\text{V}]$	243.57	220.52	195.97	169.94	146.07	121.20
$U_{WU} [\text{V}]$	113.81	102.20	90.13	77.67	66.42	54.61
$I_U [\text{A}]$	5.72	5.20	4.65	4.07	3.53	2.98
$I_V [\text{A}]$	8.53	7.70	6.83	5.93	5.11	4.29
$I_W [\text{A}]$	6.02	5.41	4.76	4.08	3.47	2.83
$P_{e,in} [\text{W}]$	807.79	669.67	536.78	411.15	311.87	225.12
$n [\text{rpm}]$	983.39	982.98	982.21	981.26	980.38	978.59
Output data						
$R_{eh} [\Omega]$	18.90	18.89	18.93	19.04	19.14	19.30
$I_{i1} [\text{A}]$	1.89	1.70	1.50	1.31	1.14	0.99
$I_{i2} [\text{A}]$	6.59	5.95	5.28	4.57	3.93	3.27
I_{i1}/I_{i2}	0.29	0.29	0.28	0.29	0.29	0.30
$P_{LL} [\text{W}]$	74.06	60.41	47.71	35.53	25.87	17.21

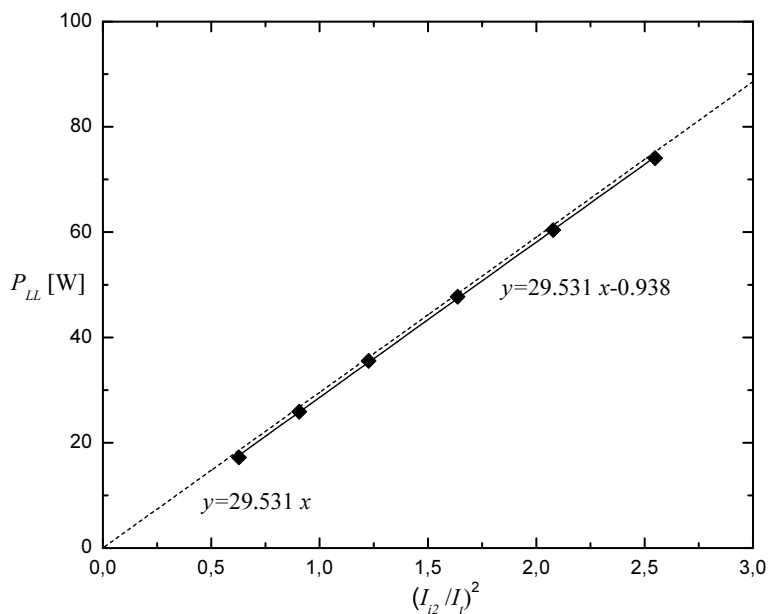

Fig. 5 – Additional losses obtained from Eh-Star test.

Table 4
Modified Eh-Star test results.

Input data						
I_{ref} [A]	8.55	7.70	6.84	5.99	5.13	4.28
U_{UV} [V]	265.50	240.53	215.05	188.98	161.17	133.44
U_{VW} [V]	160.83	145.53	130.11	114.13	97.28	80.48
U_{WU} [V]	152.84	138.98	124.40	109.49	93.18	76.89
I_U [V]	8.54	7.68	6.82	6.00	5.14	4.30
I_V [V]	8.21	7.34	6.48	5.66	4.81	3.96
I_W [V]	5.15	4.62	4.10	3.57	3.03	2.48
$P_{e,in}$ [W]	976.61	797.80	635.43	494.75	365.95	258.28
n [rpm]	976.84	976.79	975.98	975.33	973.85	970.90
Output data						
I_{i1} [A]	1.95	1.75	1.55	1.37	1.19	1.02
I_{i2} [A]	7.14	6.40	5.67	4.96	4.23	3.49
I_{i1}/I_{i2}	0.27	0.27	0.27	0.28	0.28	0.29
P_{LL} [W]	110.13	93.83	79.75	64.26	50.33	37.88

Since condition $I_{i1}/I_{i2} < 0.3$ has not been achieved in all test points during the Eh-Star test, the modified Eh-Star method has been applied. This method gives a ratio I_{i1}/I_{i2} below 0.3 at all test points. The modified Eh-Star method, when the switch in Fig. 2 is in position 3, has been performed on the same motor using the same LabVIEW application used for the Eh-Star test. So, all calculations have been performed as for the Eh-Star test.

The results obtained have been presented in **Table 4**. Variation of the stray load losses obtained from these results has been presented in Fig. 6.

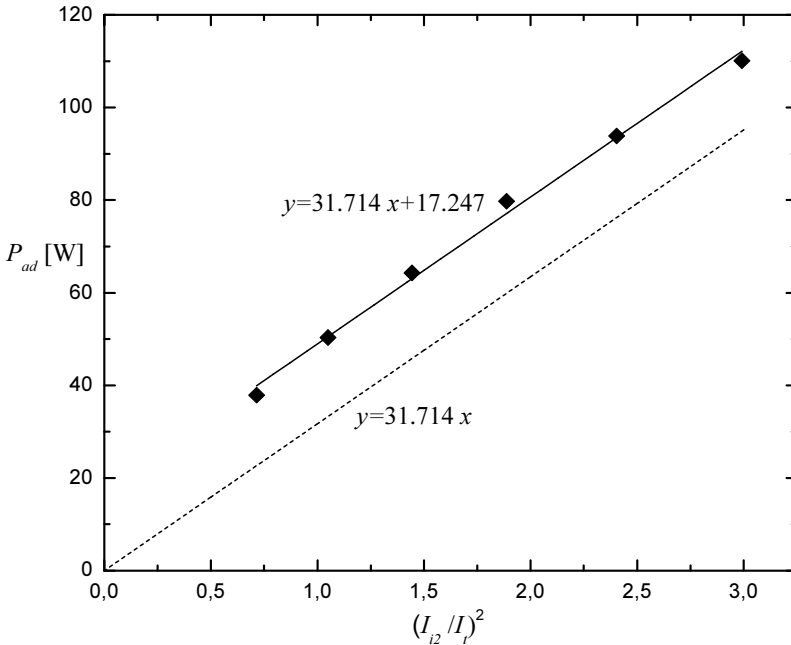

Fig. 6 – Additional losses obtained from the modified Eh-Star test.

After the offset is omitted the stray load losses for the rated load have been taken from the slope, so $P_{LL} = 31.714 \text{ W}$. This test gives a more than 7% higher stray load loss than the Eh-Star test. However, this difference is small and above 1% of the total losses. From Figs. 5 and 6 it can be seen that offset B is much greater when a modified Eh-Star test has been performed.

The results obtained from the no-load test and the Eh-Star test, along with those obtained from the load test, have been used for obtaining the efficiency of the tested motor. The motor has been started with a balanced voltage supply, when the switch in Fig. 2 is in position 1, at a rated voltage. The mechanical brake has been used as a variable motor load. The LabVIEW application has been used once more to perform measurements during the load test and to

calculate the motor efficiency at six test points. In these measurements the stray load losses have been taken as constant at $P_{LL} = 29.531 \text{ W}$. In fact these losses vary with the motor load. Nonetheless, a small error, below 1 %, has been made in this measurement (for the rated load this loss amounts to about 1.3 % of the rated power). The results obtained have been presented in **Table 5** and Fig. 7. For the rated load the result obtained is correct, and in this case it amounts 82.23%. According to IEC 60034-30 [14] with this efficiency this motor is in class IE2.

Table 5
Motor efficiency.

P/P_N	0,03862	0,43452	0,75936	1,03738	1,20075	1,39544
η [%]	22,91937	75,15454	81,16288	82,46682	82,57351	81,40425

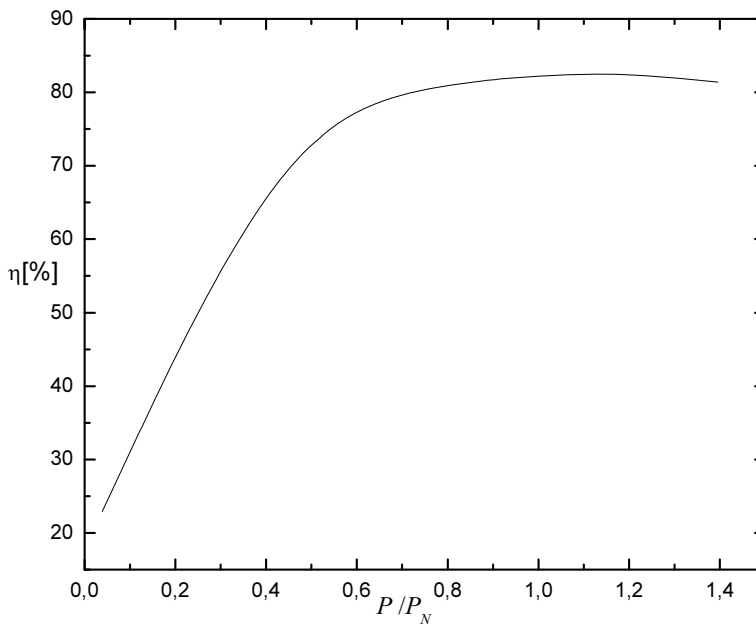

Fig. 7 – *Motor efficiency.*

5 Conclusion

This paper presents the application of the standard Eh-Star test for the measurement of stray load losses in induction motors. The determination of these losses is a key point in the accurate measurement of the energy efficiency

of an induction motor. Considering the great importance of energy efficiency it can be said that the Eh-Star test is an important step forward in its successful determination. Using this simple measurement method the stray load losses, and additionally the efficiency, of induction motors, even those with very high efficiency, can be successfully measured.

This paper presents the test circuit adopted based on the standard Eh-Star test circuit. This circuit is based on a modern data acquisition system with LabVIEW software. The LabVIEW application that runs this measurement setup has been developed and presented in this paper. Using this measurement setup and application, already fast measurement procedures can be performed even faster. All measured data can be easily stored in the PC's memory and all calculations can be performed instantly and accurately.

The results for the stray load losses of a 2.2 kW three-phase induction motor obtained by using the standard and modified Eh-Star methods have been compared. The difference in results at rated load is about 7 %, as also found in [6]. Considering the rated power and total power losses this difference has no significant effect on the motor's efficiency (about 0.1 % for the motor tested).

The influence of the resistance R_{eh} on the measured results has also been analysed. It can be seen that the achievement of $I_{i1}/I_{i2} = 0.3$ for all test points is not possible when a low power motor has been tested using the Eh-Star method. So, the application of the modified Eh-Star method may be reasonable in this case. But this method requires more power than the standard Eh-Star method, about 15 % to 20 %. So, its application for testing high power motors may be very energy consuming.

Assuming that the Eh-Star method becomes common, and that motor efficiency will increasingly be measured, it can be expected that this measuring procedure will become automated. The LabVIEW measurement setup and application presented may be the basis for creating an automated system for the measurement of stray load losses and the efficiency of induction motors. The development of an input voltage control unit and magnetic brake with a control unit, controlled by the LabVIEW application, may be a matter of future work in this area. Also, the results obtained from the Eh-Star test should be compared with those obtained by direct measurement methods. Good agreement between results can be expected as similar ones have already been obtained by other authors.

6 Acknowledgment

This paper has been supported by the Scientific Project TR 33016 financed by the Ministry of Education, Science and Technological Development of the Republic of Serbia.

7 References

- [1] H. Jordan, E. Richter, G. Röder: Ein einfaches Verfahren zur Messung der Zusatzverluste in Asynchronmaschinen. ETZ-A, Vol. 88, No. 23, 1967, pp. 577 – 583.
- [2] IEC 60034-2-1, Edition 1.0: Rotating Electrical Machines – Part 2-1: Standard Methods for Determining Losses and Efficiency from Tests (Excluding Machines for Traction Vehicles), Geneva, Switzerland, Sept. 2007.
- [3] M. Aoulkadi, A. Binder: The Eh-star Method for Determination of Stray Load Losses in Cage Induction Machines, 4th International Conference on Energy Efficiency in Motor Driven Systems, Heidelberg, Germany, 05 – 08 Sept. 2005, Vol. 1, pp. 130 – 140.
- [4] M. Aoulkadi, A. Binder: Influence of Auxiliary Impedance on Stray Load Loss Determination with Eh-Star Method, 5th International Conference on Energy Efficiency in Motor Driven Systems, Beijing, China, 10 – 13 June 2007, pp. 542 – 553.
- [5] C. Gerada, K. Bradley, J. Arellano-Padilla: An Investigation into the Suitability of Unbalanced Motor Operation, the Eh-Star-circuit for Stray Load Loss Measurement, IEEE Industry Applications Conference, Hong Kong, China, 02 – 06 Oct. 2005, Vol. 2, pp. 1329 – 1336.
- [6] A.C. Machado, J.E. de S. Pacheco, M.V. Ferreira da Luz, C.G.C. Neves, R. Carlson: Stray Load Losses Calculation Routine based on the Eh-Star Method, International Conference on Electrical Machines, Vilamoura, Portugal, 6 – 9 Sept. 2008, Paper ID 1291.
- [7] A.T. de Almeida: Technical Harmonization Issues, Motor Summit 2007, Zurich, Switzerland, 9 – 11 April 2007.
- [8] P. Angers, D. Friesen: Comparison of Test Methods for the Determination of Measured Efficiency. Motor Summit 2007, Zurich, Switzerland, 9 – 11 April 2007.
- [9] M. Aoulkadi, A. Binder: Comparison of Different Measurement Methods for Stray Load Losses in Cage Induction Machines: Input-output Method, RRT method and Eh-Star Method, 40th International Universities Power Engineering Conference, Cork, Ireland, 7 – 9 Sept. 2005, Paper ID 75.
- [10] M. Aoulkadi, A. Binder: Evaluation of Different Measurement Methods to Determine Stray Load Losses in Induction Machines, International Symposium on Power Electronics, Electrical Drives, Automation and Motion, Taormina, Italy, 23 – 26 May 2006, pp. S1-13 – S1-18.
- [11] M. Aoulkadi, A. Binder: Comparison of Different Evaluation Methods to Determine Stray Load Losses in Induction Machines with Eh-Star Method, IEEE Transactions on Industry Applications, Vol. 44, No. 6, Nov/Dec. 2008, pp. 1675 – 1682.
- [12] IEC 61972, Edition 1.0: Method for Determining Losses and Efficiency of Three-phase Cage Induction Motors, Geneva, Switzerland, July 2002.
- [13] IEEE Standard 112-2004: IEEE Standard Test Procedure for Polyphase Induction Motors and Generators, New York, USA, Nov. 2004.
- [14] IEC 60034-30, Edition 1.0: Rotating Electrical Machines - Part 30: Efficiency Classes of Single-speed, Three-phase, Cage-induction Motors, Geneva, Switzerland, Oct. 2008.
- [15] B. Koprivica, A. Milovanovi, M. Djekic: Determination of Characteristics of Ferromagnetic Material using Modern Data Acquisition System, Serbian Journal of Electrical Engineering, Vol. 6, No 3, Nov. 2009, pp. 451 – 459.
- [16] M. Bjekic, D. Stojanovic, A. Milovanovic, B. Koprivica, M. Rosic, M. Bozic, M. Plazinic, S. Antic, D. Bjekic, R. Krneta, B. Jefenic, S. Statkic, M. Bebic, L. Ristic: Energy Efficiency of Electric Drives, Technical Faculty Cacak, Cacak, Serbia, 2012 (in Serbian).